

# SwitchBlox Rugged

## Small Rugged 5 port 10/100Mbps Ethernet Switch

MPN: BB-SWR-G-1 (PicoBlade Variant)  
MPN: BB-SWR-G-1-PC (PicoClasp Variant)

## Datasheet

May 2024  
Board revision G

# Contents

<b>Contents</b>	<b>2</b>
<b>1 General Information</b>	<b>3</b>
1.1 Functionality and Features of SwitchBlox Rugged	3
1.1.1 Features	3
1.1.2 General Information	3
1.1.3 General Operating Instructions	4
1.2 Safety Information	4
1.3 Block Diagram	5
1.4 Included Equipment	6
1.5 RoHS Certification of Compliance	6
<b>2 Hardware Interfaces</b>	<b>7</b>
2.1 Board Map	7
2.2 Connectors and Pinouts	8
2.2.1 Voltage Input	8
2.2.2 Ethernet Ports	10
2.2.3 Extension RGMII header	12
2.2.4 Using the RGMII header for Back-to-back or Rugged SOM assemblies	12
2.2.4 SWD Programming Header	14
2.2.5 External LED header	14
2.2.6 UART Header	15
2.3 Other Interfaces	16
2.3.1 LEDs	16
<b>3 Software Interfaces</b>	<b>18</b>
3.1 Static Firmware	18
3.2 BloxOSLite Command Line Interface	18
<b>4 Device Configuration</b>	<b>19</b>
4.1 Unmanaged Switch	19
4.2 Managed Switch	19
<b>5 Device Characteristics</b>	<b>19</b>
5.1 Operating Conditions	19
<b>6 Datasheet Changelog</b>	<b>20</b>
<b>7 Contact</b>	<b>20</b>
<b>8 Certificate of Conformity</b>	<b>21</b>

# 1 General Information

## 1.1 Functionality and Features of SwitchBlox Rugged

SwitchBlox Rugged is a rugged form factor 5 port 10/100Mbps (10BASE-T/100BASE-TX) Layer 2 unmanaged and managed ethernet switch. It has a non-blocking fabric meaning that 100Mbps speed can be achieved simultaneously on all ports. It is a very small form factor Ethernet Switch designed for the harshest applications, which can operate from -40°C to 105°C.

It runs from a wide input voltage range of 5 to 60V, features PoE injection onboard, and houses a microcontroller for custom firmware upload.

The board is stackable so that two boards can be combined to create a 10 port switch.

### 1.1.1 Features

- 5 x 10/100M (10BASE-T/100BASE-TX) ethernet ports
- Input voltage range from 5 to 60V
- Reverse protected voltage input
- Transient protected voltage input
- -40°C to 105°C operation range
- Stackable header to allow two boards to be stacked to make a 10 port switch
- 44.5mm x 44.5mm board size
- Molex PicoBlade or PicoClasp connectors for power and ports
- Automatic MDI-X crossover
- Unmanaged (out-the-box) functionality
- Port Activity Indicators with breakout header
- UART header for switch management (currently not implemented)

### 1.1.2 General Information

<b>Voltage Input</b>	5V to 60V DC (65V absolute max)
<b>PoE Maximum Power Output</b>	N/A
<b>Supported Protocols</b>	10BASE-T, 100BASE-TX
<b>Power Consumption</b>	600mW (idle) to 1200mW (full switching)
<b>Weight</b>	16 grams
<b>Size</b>	44.5mm x 44.5mm x 11.17mm
<b>Operating Temperature</b>	-50°C to +110°C

<b>Storage Temperature</b>	-55°C to +125°C
----------------------------	-----------------

*Table 1: General Information*

### 1.1.3 General Operating Instructions

SwitchBlox Rugged is designed for use in harsh environments, operating from a nominal supply voltage of 24V, but with the ability to operate from as low as 5V and as high as 60V.

In the simplest case of an unmanaged switch application, SwitchBlox Rugged can be operated immediately by following the following steps.

- 1) Apply a voltage between 5V to 60V to the voltage input terminals.
- 2) Connect external devices to the ethernet ports using RJ45 to Picoblade cables.
- 3) SwitchBlox Rugged will automatically begin auto negotiation with connected devices and begin receiving and forwarding packets to/from all connected devices.

*Revision G of this board contains a more powerful microcontroller than revision F. In the future, this will allow SwitchBlox Rugged to run the same CLI interface as UbiSwitch. For now, this feature is unimplemented.*

## 1.2 Safety Information

- This device can operate on voltages near and above 60V. Please read this manual before operating.
- This device is provided “as is”. In-application testing prior to integration is recommended.
- This device is provided as an electronic circuit board, and requires integration into chassis for full ingress protection.
- Do not use this product in wet environments without integrating into a chassis.
- Do not operate this product beyond the rated temperature and voltages.

### 1.3 Block Diagram

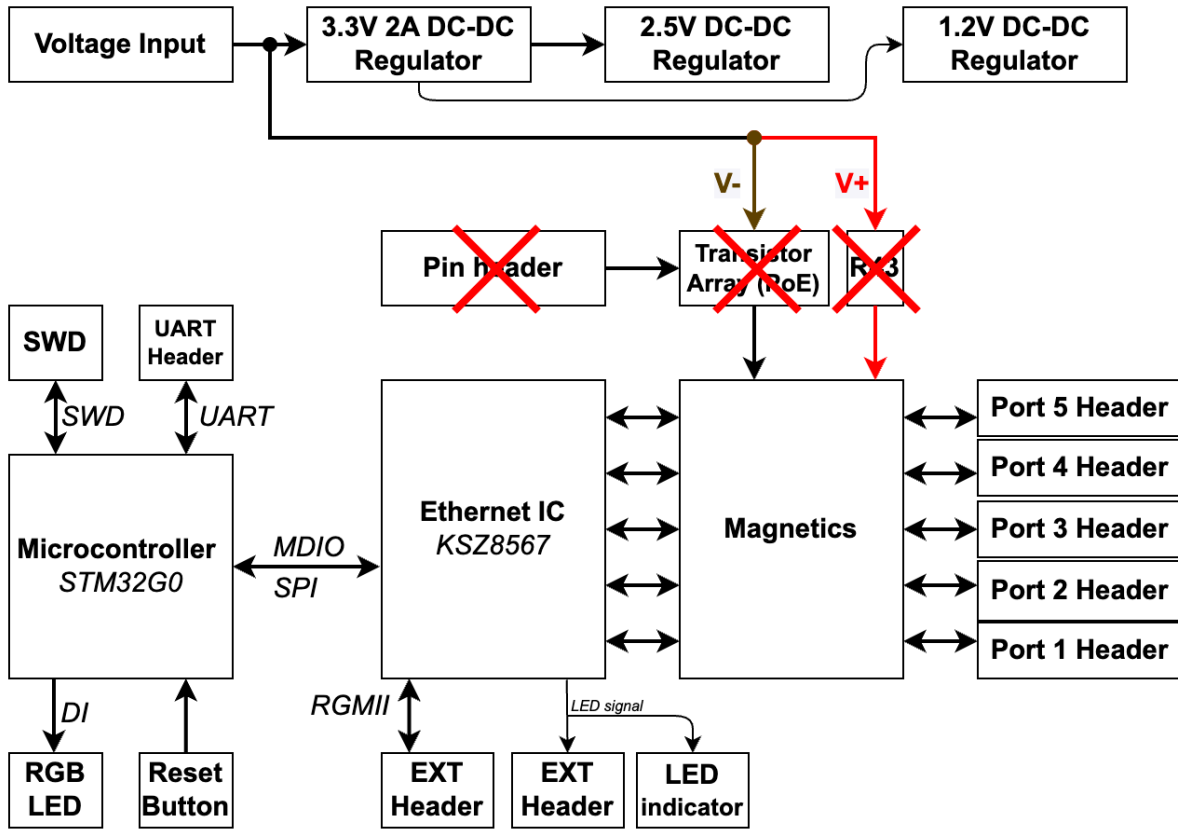

Figure 1: SwitchBlox Rugged Block Diagram, red crosses show components removed on Revision F and Revision G

## 1.4 Included Equipment

The product includes the following:

1 x SwitchBlox Rugged board

5 x Molex Picoblade to RJ45 4-way Unshielded Twisted Pair cables (300mm)

1 x Molex Picoblade to bare, tinned leads (300mm)

## 1.5 RoHS Certification of Compliance

The BotBlox SwitchBlox Rugged complies with the RoHS (Restriction of Hazardous Substances Directive) Certificate of Compliance.

## 2 Hardware Interfaces

### 2.1 Board Map

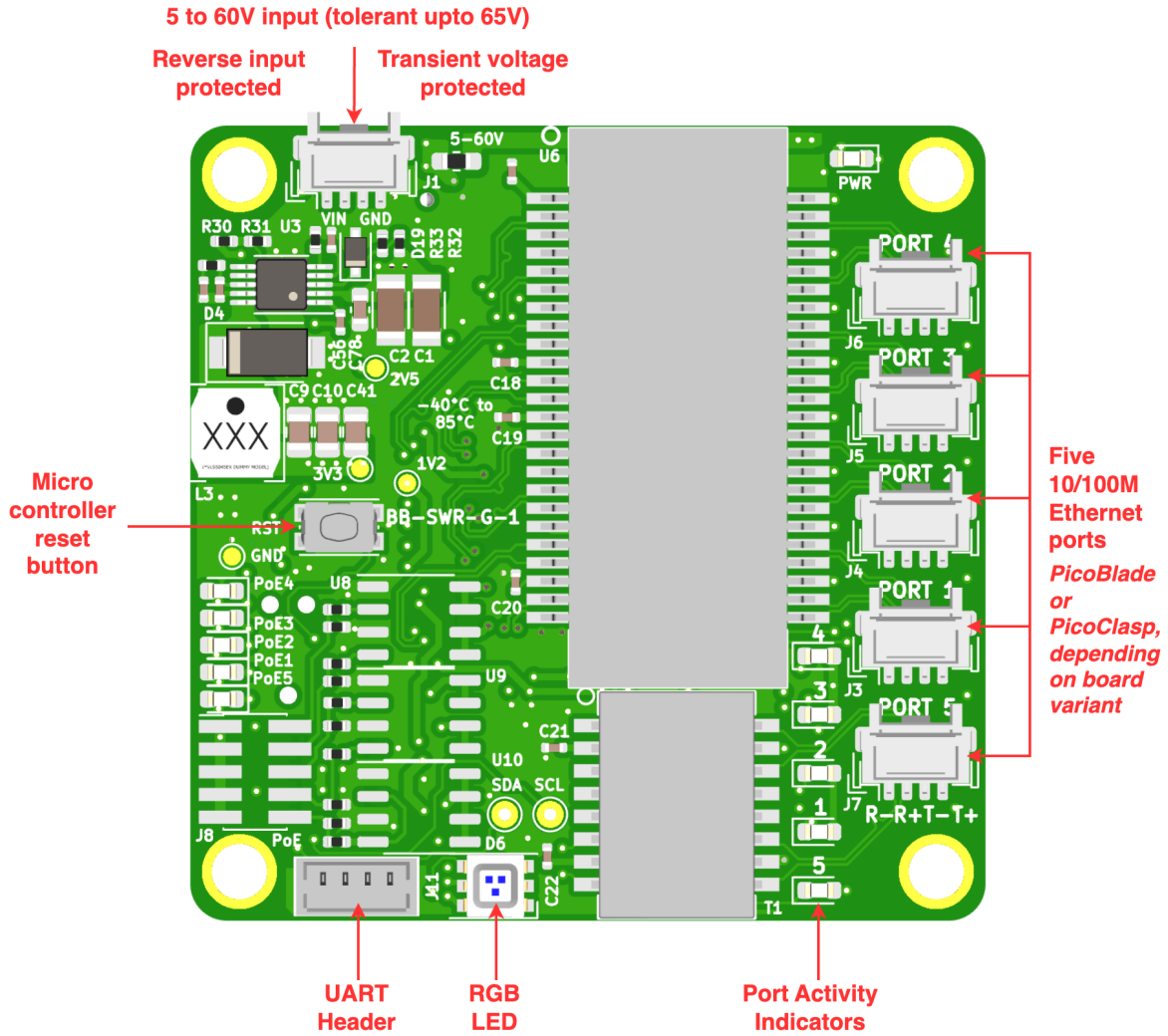

Figure 2: SwitchBlox Rugged Board Map (front)





The pinout of the voltage input connector is shown in figure 4 below.

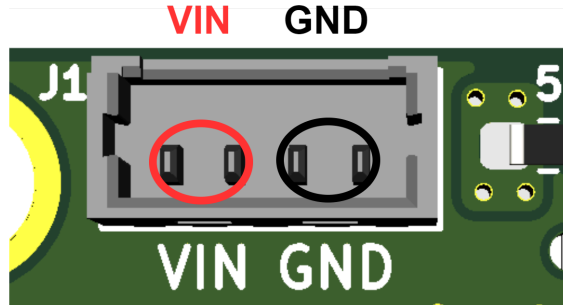

Figure 4: Voltage input header pinout for the Molex PicoBlade variant

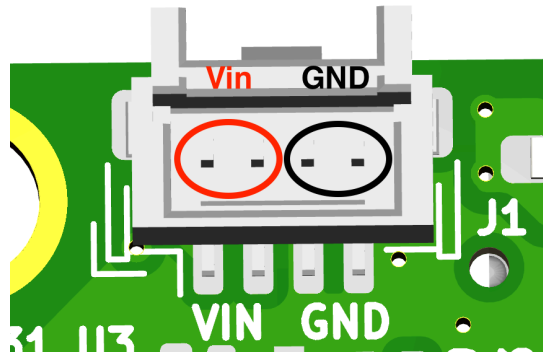

Figure 5: Voltage input header pinout for the Molex PicoClasp variant

#### Connector part numbers

Connector on board	Mating header	Crimp used	Wire used
<a href="#">10114829-10104LF</a> (For BB-SWR-G-1, PicoBlade version)	<a href="#">10114826-00004LF</a> (For BB-SWR-G-1, PicoBlade version)	<a href="#">500798000</a> (For BB-SWR-G-1, PicoBlade version)	UL1061, 28AWG
<a href="#">5019400407</a> (For BB-SWR-G-1-PC, PicoClasp version)	<a href="#">5019390400</a> (For BB-SWR-G-1-PC, PicoClasp version)	<a href="#">5011937000</a> (For BB-SWR-G-1-PC, PicoClasp version)	UL1061, 28AWG

Table 2: Voltage input connector pinout and part numbers



Figure 6: Voltage input cable pinout for Molex PicoBlade (red = V+, black = GND)

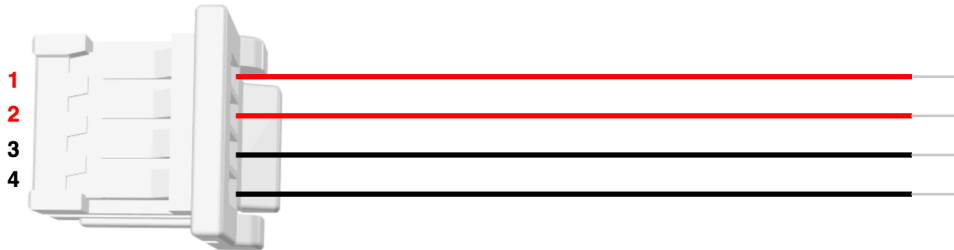

Figure 7: Voltage input cable pinout for Molex PicoClasp (red = V+, black = GND)

### 2.2.2 Ethernet Ports

There are five ethernet connectors on SwitchBlox Rugged. Each connector has four pins corresponding to the four signals required for 100BASE-TX which are R-, R+, T-, T+.. The pin mapping of all five connectors is identical.

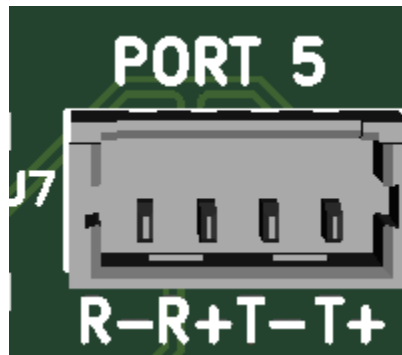

Figure 8: Ethernet port pinout for the Molex PicoBlade variant

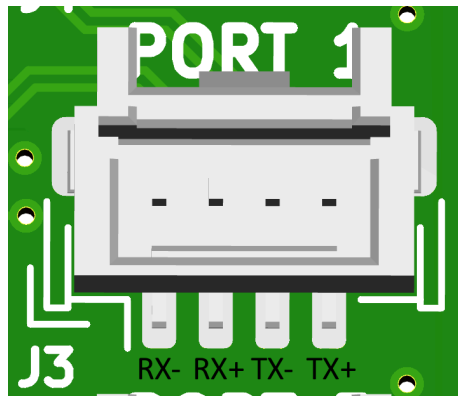

Figure 9: Ethernet port pinout for the Molex PicoClasp variant

Connector on board	Mating header	Crimp used	Wire used
<a href="#">10114829-10104LF</a> (For BB-SWR-G-1, PicoBlade version)	<a href="#">10114826-00004LF</a> (For BB-SWR-G-1, PicoBlade version)	<a href="#">500798000</a> (For BB-SWR-G-1, PicoBlade version)	UL1061, 28AWG
<a href="#">5019400407</a> (For BB-SWR-G-1-PC, PicoClasp version)	<a href="#">5019390400</a> (For BB-SWR-G-1-PC, PicoClasp version)	<a href="#">5011937000</a> (For BB-SWR-G-1-PC, PicoClasp version)	UL1061, 28AWG

Table 3: Ethernet connector pinout and part numbers

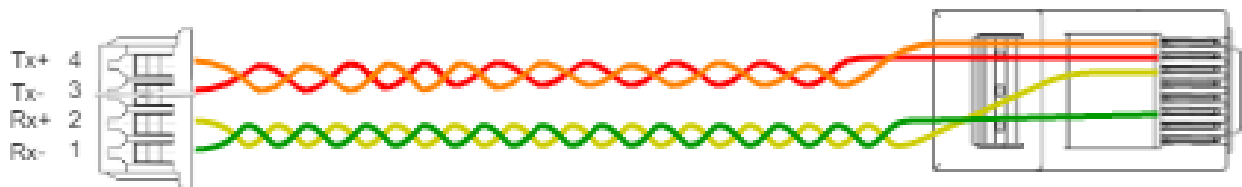

Figure 10: Ethernet cable pinout for Molex PicoBlade variant

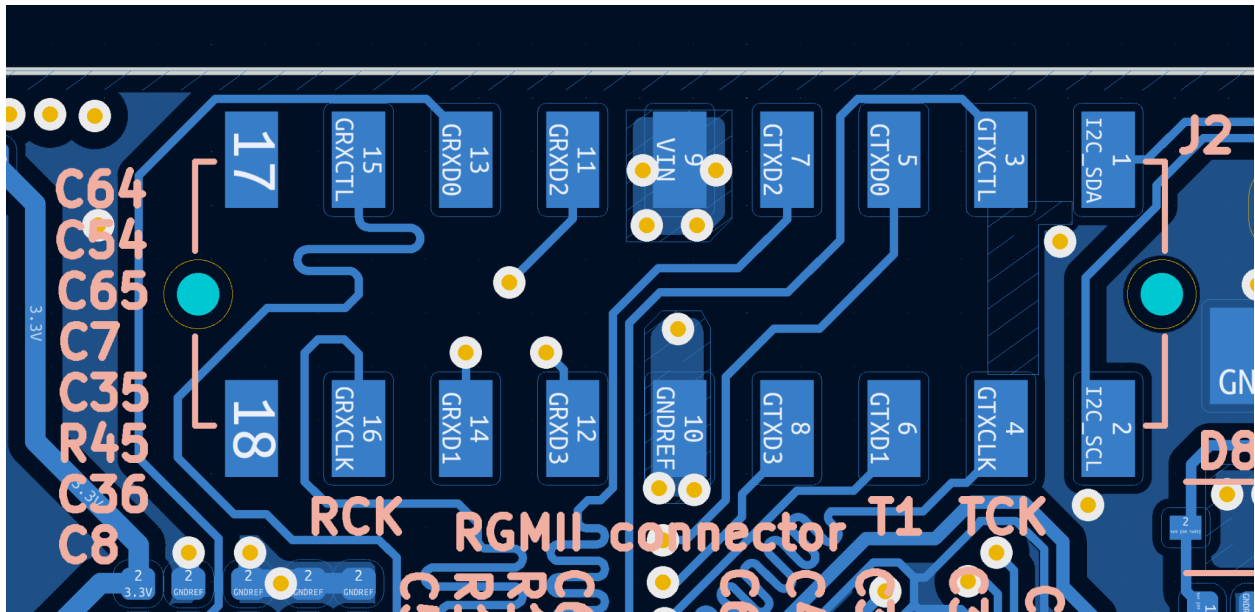

Figure 11: Ethernet cable pinout for Molex PicoClasp variant

### 2.2.3 Extension RGMII header

SwitchBlox Rugged exposes RGMII and the I2C management bus on a stackable header, for board stacking purposes. This connection allows two boards to be stacked to form a 10 port switch. It also allows SwitchBlox Rugged to be stacked with Rugged SOM for full switch management. Stacking two SwitchBlox Rugged together to form a 10 port switch requires no additional configuration, however some minor additional mounting hardware is required:

- 1 x 16 position pin header (MPN: [M22-2520805](#))
- 4 x 8mm hex standoffs (MPN: [24382](#))
- 4 x M2.5 machines screws (MPN: [29300](#))



*Figure 12: Extension RGMII header pinout, Rx in this case refers to the received data from the switch, therefore is an output from this board. Tx is an input to this board. This is consistent with the PHY side of the RGMII*

### 2.2.4 Using the RGMII header for Back-to-back or Rugged SOM assemblies

The 16 pin header for SwitchBlox Rugged can be plugged into the 18 pin header in either a left justified position (pins 1 and 2 are left unconnected) or a right justified position (pins 17 and 18 are left unconnected). How the pin header needs to be connected depends on whether you are connecting two SwitchBlox Rugged together to form a 10 port switch, or whether you are connecting a SwitchBlox Rugged to a Rugged SOM to form a managed switch.

For SwitchBlox Rugged to SwitchBlox Rugged (back-to-back) applications, you must connect the pin header in a left justified position, so that the I2C pins (pins 1 and 2) do not connect between both boards. This allows each board to maintain an isolated I2C management bus and is essential for correct operation.

For SwitchBlox Rugged to Rugged SOM (managed) applications, you must connect the pin header in a right justified position, so that the I2C pins (pins 1 and 2) are connected between both boards. This allows Rugged SOM to access the I2C management bus on SwitchBlox Rugged.



*Figure 13: Back to Back operation (two SwitchBlox Rugged)*

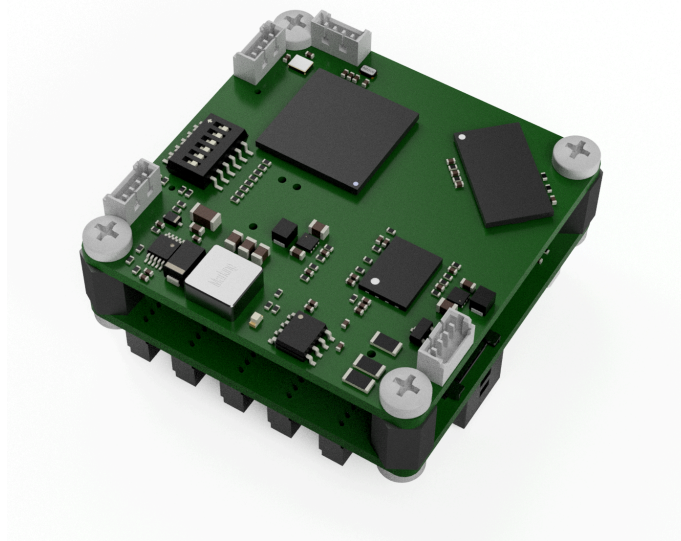

*Figure 14: Managed operation (SwitchBlox Rugged + Rugged SOM)*

### 2.2.4 SWD Programming Header

A programming header on the back of the board allows firmware to be flashed onto an STM32 microcontroller, when installed on SwitchBlox Rugged.

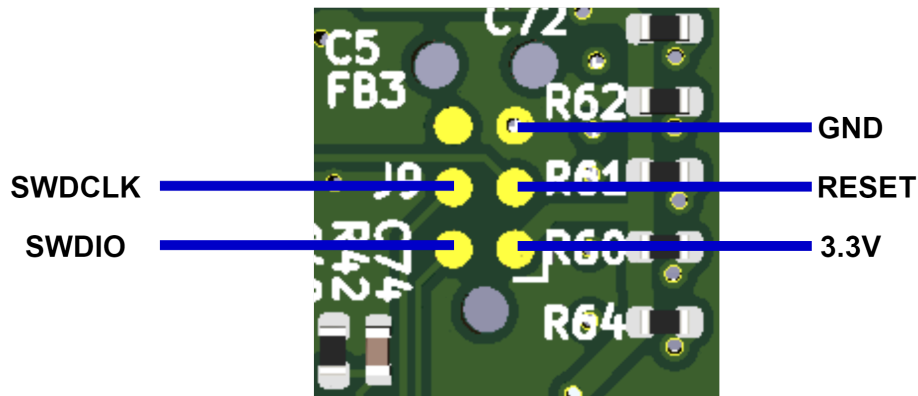

Figure 15: SWD programming header pinout

This header allows access to the SWD port on the a STM32 microcontroller (if mounted on the board), and requires the use of a 6-pin needle adapter such as the [J-Link 6-pin needle adapter](#) along with an in-circuit programmer such as the [J-Link](#).

### 2.2.5 External LED header

An external LED header on the back of the board allows port activity indicator signals to be brought off - board for integration into a chassis. The LED signals are provided in a common anode configuration. The anode of all external LEDs should connect to the 3.3V on the External LED header, and the cathode of the external LED should connect to the corresponding “Px” connection on the header. These connections already include a 1kΩ current limiting resistor in series with the cathode connection; this means you do not need to add an external current limiting resistor. Figure 17 shows the pinout and an example of how to connect an external LED.

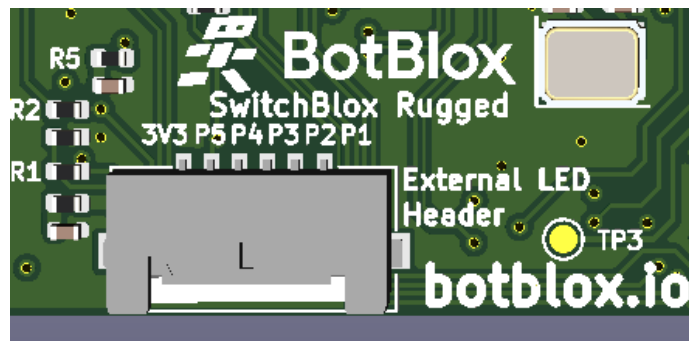

Figure 16: External LED header

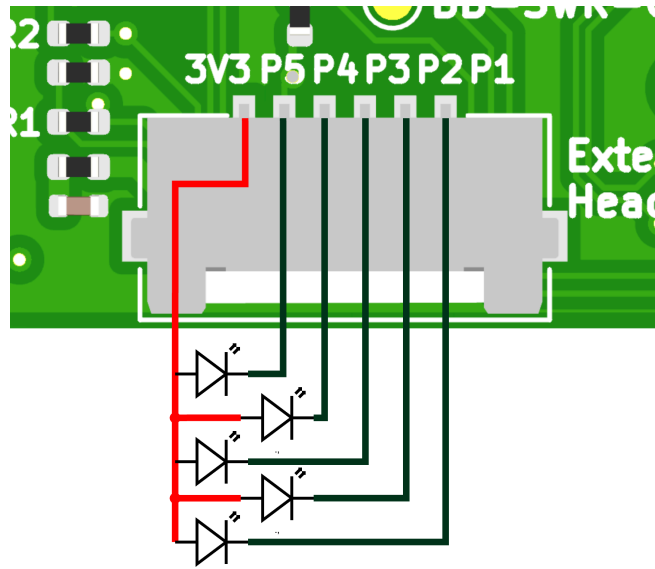

Figure 17: An example of how to wire external LEDs onto the external LED header

Connector on board	Mating header	Crimp used	Wire used
<a href="#">5037630691</a>	<a href="#">5037640601</a>	<a href="#">5037650098</a>	UL1061, 28AWG

Table 4: The connectors and associated mating parts used on the external LED header



Figure 18: LED breakout cable diagram

### 2.2.6 UART Header

The board contains a 3.3V TTL level serial (UART) breakout header that connects directly to the embedded microcontroller. This allows an external device to be connected to the board for the purposes of switch management. At time of writing, this feature is unimplemented; in the future, this will take the form of a command line interface that allows parameters of the switch to be managed.

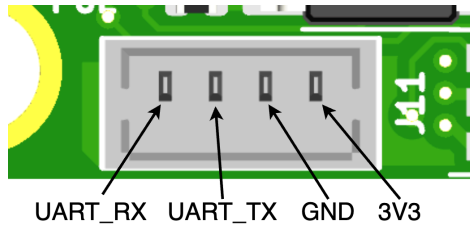

Figure 19: UART header

UART\_RX is an input to SwitchBlox Rugged, and needs to be connected to TX on the connected device. UART\_TX is an output from SwitchBlox Rugged and needs to be connected to RX on the connected device.

Note that there is no protection on these pins, they are connected directly to the onboard microcontroller. Therefore it is crucial you ensure that the connected device is also a 3.3V level TTL serial port, and that the grounds between both devices are connected. This UART port is designed for short connections within a subassembly, it is not suited to long cable runs across noisy environments (RS485 is a better alternative for such applications).

Connector on board	Mating header	Crimp used	Wire used
<a href="#">10114829-10104LF</a>	<a href="#">10114826-00004LF</a>	<a href="#">500798000</a>	UL1061, 28AWG

Table 5: The connectors and associated mating parts used on the external LED header



Figure 20: UART cable diagram

## 2.3 Other Interfaces

### 2.3.1 LEDs

There are 12 LEDs on SwitchBlox Rugged in total. Five of the LED signals can be taken off board.

The 3.3V Power Indicator LED (**Green**) indicates that voltage is present on the 3.3V line. It should be solid green in normal operation.



Each Port Activity LED (**Green**) corresponds to a specific port. They indicate activity on each port and will blink when there is traffic on a port. They should be solid off when a port is not connected to any device, and they should blink under normal operation. A solid green LED indicates either constant traffic, or a fault with the port.

The PoE on Port Indicator LEDs (**Orange**) indicates which of the ports currently has PoE injected onto it. This can be toggled on a port-by-port basis using the PoE Select DIP switch. These LEDs are no longer populated from revision F and onwards, because the PoE functionality has been deprecated.

The RGB LED is controlled entirely by the onboard microcontroller, therefore is only used in managed applications for signaling status.

## 3 Software Interfaces

### 3.1 Static Firmware

Static firmware refers to routines that run on the onboard microcontroller to provide specific switch configurations that are static from runtime. Such firmware cannot be interacted and is typically used to provide specific combinations of configurations on the switch.

Static firmware is a useful tool for fixing specific issues related to switch connections (such as auto-negotiation problems), or providing fixed configurations on features such as VLANs. Static firmware is not a scalable solution for customer configuration of the switch.

Reach out to us at [info@botblox.org](mailto:info@botblox.org) if you believe you have a need for a static firmware configuration on SwitchBlox Rugged.

### 3.2 BloxOSLite Command Line Interface

BloxOSLite CLI is a software tool that is currently under development. This tool will be deployed on SwitchBlox Rugged and provide a command line interface to the user with a set of commands for dynamic volatile and non-volatile configuration of the switch. This software will bring a new suite of capabilities to SwitchBlox Rugged, once complete.

## 4 Device Configuration

### 4.1 Unmanaged Switch

To use SwitchBlox in an unmanaged application requires no configuration. Simply connect a voltage to the voltage input and connect downstream devices.

### 4.2 Managed Switch

Please refer to 3 Software Interfaces for more information on how to achieve managed switch functionality.

## 5 Device Characteristics

### 5.1 Operating Conditions

#### 5.1.1 Absolute Maximum Ratings

Operating in these ranges will reduce the lifetime of the device.

<b>Voltage Input Maximum</b>	65V
<b>Storage Temperature</b>	-55°C to +125°C
<b>Operating Temperature</b>	-50°C to +110°C

#### 5.1.2 Nominal (Test) Ratings

<b>Voltage Input</b>	65V
----------------------	-----

## 6 Datasheet Changelog

Date	Datasheet Version	Author	Notes
29/05/2021	ABC_A	Binh Ngyuen	Initial release
25/06/2021	ABC_B	Josh Elijah	Fixed the incorrect crimp terminal MPN stated for the connectors
21/02/2022	D_A	Josh Elijah	Revision D edit
30/01/2023	D_E	Josh Elijah	Revision E edit
20/09/2023	F_A	Josh Elijah	Revision F edit
25/10/2023	F_B	Jaclyn Li	Table 1.1.2 General Information updated to be correct values.
14/03/2024	G_A	Josh Elijah	Revision G edit
01/05/2024	G_B	Jaclyn Li	Updated operating temperature range from “-40°C to +105°C” to “-50°C to +110°C”

## 7 Contact

If you have any questions regarding this product, please contact us:

info@botblox.org  
4 Pavilion Court 600 Pavilion Drive,  
Northampton Business Park,  
Northampton,  
England  
NN4 7SL

## 8 Certificate of Conformity

The full text of the Certificate of Conformity of this product is available at the following web address. <https://botblox.io/documentation/>